

Laser distance sensor

OPTImess MLC CCD



- Large measuring ranges
- High measuring rate
- High precision
- Digital measurement processing
- Analogausgang oder CAN-Bus

The optoelectronic sensor OPTIMESS MLC CCD is used for non-contact distance measurement. This sensor is characterized by its extensive independence of measurement accuracy on different material surfaces and ambient light.

OPTIMESS MLC CCD works according to the triangulation principle. Due to its robustness, the sensor is particularly suitable for use on vehicles, e.g. for road transverse and longitudinal profile measurements as well as vehicle dynamics measurements where larger measuring ranges are required. The laser point projected by a laser diode using optics is imaged at an angle on a CCD line by receiving optics. The processor integrated in the sensor processes the optical distance information and outputs it as an analog value or via the CAN bus.



Robotik



Profilmessung



Stahlindustrie,
Industrielle
Automation



Eisenbahn

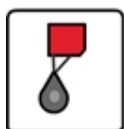

Dynamische
Konturmessung

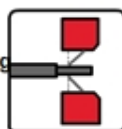

Dicken-
messung



Gummi- und
Reifenmessung

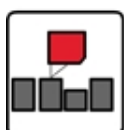

Abstandsmessung,
Lagekontrolle



Autoindustrie

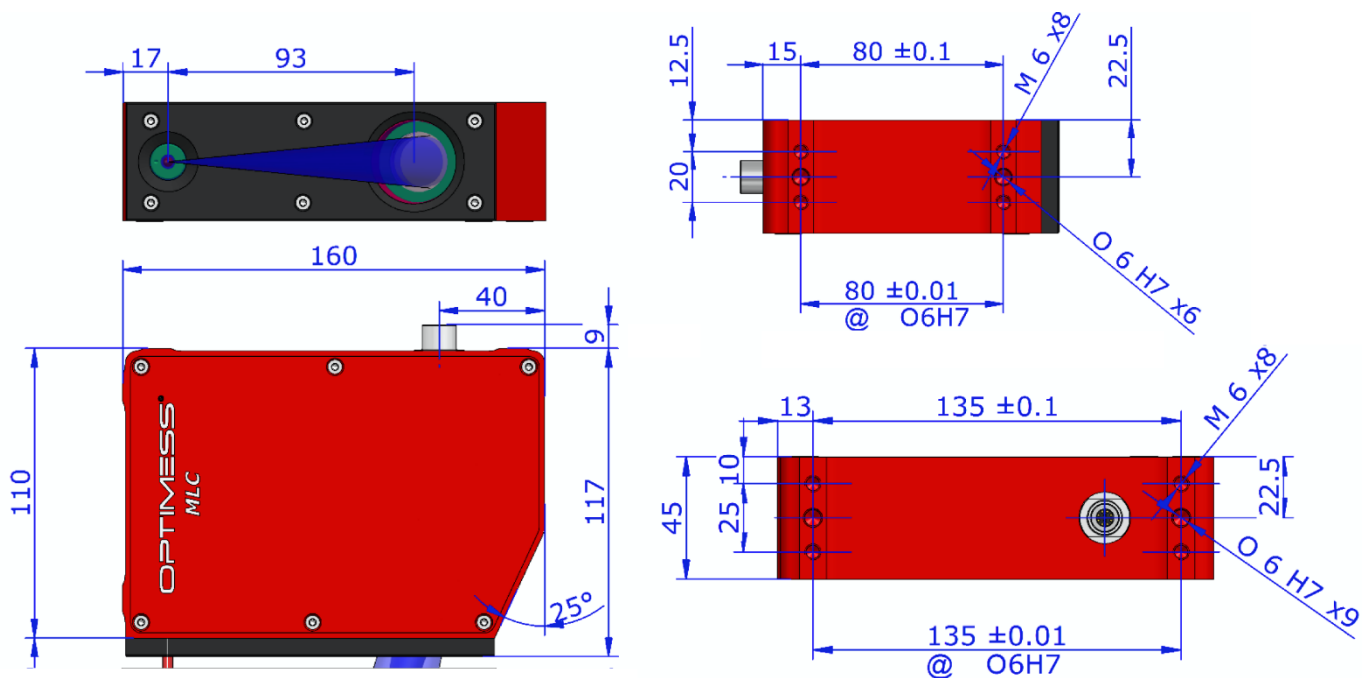

	OMS 4620	OMS 4630	OMS 4640	OMS 4650	OMS 4660	OMS 4680	OMS 4700	OMS 4760
Measuring range [mm] [*]	200	300	400	500	600	800	1000	1600
Stand off [mm] [*]	300	400	500	600	800	1000	1200	2000
Resolution [mm] [*]	0,02	0,03	0,04	0,05	0,06	0,08	0,10	0,20
Linearity	≤± 0.06% of measuring range							
Reproducibility	≤≤ 0.03% of measuring range							
Filter type [*]	Digital averaging							
Measuring rate *2]	50 kHz max.							
Ambient light	➤ 100.000 Lux (sunlight)							
Wavelength [*]	405 - 850 nm							
Laser class [*]	1 / 2 / 3R / 3B							
Vibration	10 – 100 Hz, 2mm							
Power supply	10 - 32VDC							
Output signal [*]	± 5V / ± 10V / 0 - 5V / 0 - 10V / 0 - 20mA / 4 - 20mA / CAN - Bus							
Temperature range	-20°C bis 60°C non-condensing							
Dimensions	160 x 117 x 45mm							
Weight	1,1kg							
Protection class	IP 67 (even when unplugged)							
Humidity	5% - 95%, non-condensing							

[*] Specifications may vary and are provided on the data sheet provided with each sensor